

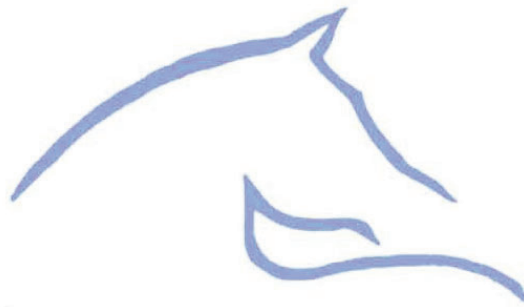

**TRI-STATE HORSEMEN'S
ASSOCIATION, INC.**



Approved
Class Specifications & Divisions
For Season Championships

Revised March 2023



*Tri-State Horsemen's Association
Approved Class Specifications & Divisions*

TABLE OF CONTENTS

	<u>Page #</u>
General Information.....	3
Academy Division.....	3
Open Schooling Division.....	4
Leadline Division.....	5
Dressage Schooling Division.....	5
Arabian/Half Arabian.....	6
Registered Morgan Divisiion.....	7
Registered Hackney Pony Division.....	8
Registered American Saddlebred Division.....	9
Saddle Seat Equitation Division.....	11
Open Performance Division.....	12
Registered Tennessee Walking Horse Division.....	13
Ranch Horse Division.....	15

Tri-State Horsemen's Association

Approved Class Specifications & Divisions

For Season Championships

NOTE TO ALL MEMBERS: ALL Tri-State members are eligible to compete in any Tri-State approved show; HOWEVER, Tri-State members wishing to compete for year-end awards must also pay additional recording fees to be eligible: \$20 per horse or \$20 per Equitation, Showmanship, Open Schooling/Academy/Leadline Division or Dressage Exhibitor. **Points will be recorded only after payment of BOTH the annual dues and recording fees has been received.**

- Points will be counted for horses and/or riders only if entered under the correct membership owner name
- For horse show purposes, the age of a rider on last Dec. 1st shall be maintained throughout the following year.
- The birth date of a horse shall be January 1st (regardless of foaling date.)

For further information, write Tri-State Horsemen's Association, 15460 Pioneer Trail, Eden Prairie, MN 55347.

NOTE TO APPROVED SHOWS: This class list is comprised of the classes most wanted by your faithful exhibitors, the members of Tri-State, and is to be used in conjunction with the current "Official Rulebook." Please familiarize yourselves with both publications. When making up your prize list, please bear in mind that "judges must be qualified for each Tri-State approved class and may be selected from listings of approved judges as published by pertinent horse organizations." Any further questions or information should be directed to your Tri-State appointed show advisor or Board Member. Please use exact specifications listed.

USEF recognized shows which require more detailed specifications shall use their current Rule Book. Tri-State shows not recognized by USEF shall incorporate the rules outlined in the USEF Rule Book, refer to their appropriate national organization rules or establish and publish their own criteria. No point credit will be given to classes more restrictive than those listed, unless complementary sections are offered.

ANY CHANGES IN THE CURRENT USEF RULE BOOK AUTOMATICALLY BECOME A PART OF THESE SPECIFICATIONS.

NOTE: Every attempt is made to keep these rules up-to-date. However, each exhibitor should consult the USEF rules regarding their breed or discipline for any recent changes that may be relevant to their competition. A written copy of the rulebook is available or can be read on-line at www.usef.org.

ALL DIVISIONS: Points will be counted for all stake classes unless more restrictive than the classes listed. Points will be counted in any championship class that has been split as long as the sections are complementary (Example: Arabian Western Pleasure-Mares/Geldings, and Arabian Western Pleasure-Stallions.)

POINT SYSTEM: Horses or riders must SHOW and PLACE in the same approved Tri-State class in at LEAST THREE SHOWS UNDER AT LEAST TWO DIFFERENT JUDGES to be eligible for a Championship. (Points are counted as follows:

1st - 20 pts ♦ 2nd - 16 pts ♦ 3rd - 12 pts ♦ 4th - 8 pts ♦ 5th - 4 pts ♦ 6th - 1 pt

If there are fewer than three (3) entries in any given class, half points will be counted for that class: 1st -10 pts., 2nd - 8 pts.

POINTS WILL NOT BE COUNTED UNTIL CURRENT DUES AND NOMINATION FEES ARE PAID. In case of joint ownership. ALL owners of the horse(s) must be members of Tri-State for points to be counted (exceptions: married couples and junior exhibitors) and at least one owner must pay the NOMINATION fee.

Tri-State approval is available for multi-breed shows which offer a minimum of twelve (12) Tri-State classes from the current approved class list. Precise division rating requirements for one-breed affiliated shows are contained in the following approved class list. We encourage shows to meet them.

Academy Division

The Academy Division is only open only to riders who have never competed in a regular horse show in full show attire in their respective division. Riders must be competing on an Academy Horse. A rider who has been shown and judged in Walk/Trot/Canter classes is no longer eligible to compete in Walk/Trot classes.

The Academy Horse is defined as a horse of any breed that is regularly used in a professionally operated lesson program. An Academy horse may be privately owned, however, the horse must earn his living as a lesson horse.

The Academy horse must display safe manners and characteristics desired of a lesson horse. Horses are not to be judged; way of going is not considered. Only the rider is judged in Academy Classes. The horse must be tacked as if giving a riding lesson and the saddle must be consistent with the style of riding. In English Pleasure and Saddle Seat Equitation, full bridles are acceptable but use of the full bridle is not to be considered an advantage by the judge. Horses should be neatly presented. Hoof black is optional.

Full show attire is not allowed including hunt coats, saddle suits, and/or western show outfits. Acceptable attire is appropriate to the seat ridden. Saddle Seat: Jodhpurs or dark long pants, dress shirt, tie, boots or jodhpur boot. Hunt Seat: Breeches, ratcatcher shirt, paddock or tall English riding boots. Western: Jeans, appropriate dress shirt and western boots. Vests, sweater vests or sweaters optional. No sport shoes or derbies allowed. Hair to be neat, up and out of the way of the exhibitor's number. **Protective helmets that meet or exceed ASTM standards are encouraged in all seats.**

Classes are to be worked both ways of the ring at the gaits required for that class. Horses should not be asked to back, to perform an extended trot or hand gallop. Headers are to be allowed in the ring for the lineup in any Academy class at the discretion of the instructor. **Headers are REQUIRED in all Walk/Trot classes.**

Academy classes are divided into pleasure and equitation divisions. Equitation classes are to be judged on basic equitation skills including but not limited to correct diagonals and leads with an emphasis on the rider's ability to present his/her horse to the best of the horses' ability. The impression of efficient, complete control must be demonstrated.

In Academy Pleasure classes, the rider will be judged on his/her ability to control and show the horse including manners and ring performance.

Points will be counted within appropriate age groups. Only classes designated as "Academy" classes count for year-end awards in the Academy division.

ACD-1. Saddle Seat English Pleasure (Rider any age)

To be shown at a walk, trot and canter.

ACD-2. Saddle Seat English Pleasure – Walk/Trot

To be shown at a walk and trot.

ACD-3. Saddle Seat Equitation (Rider any age)

To be shown at a walk, trot and canter.

ACD-4. Saddle Seat Equitation – Walk/Trot

To be shown at a walk and trot.

ACD-5. Hunter Pleasure (Rider any age)

To be shown at a walk, trot and canter.

ACD-6. Hunt Seat Equitation

To be shown at a walk, trot and canter.

ACD-7. Hunter Pleasure – Walk/Trot

To be shown at a walk and trot.

ACD-8. Hunt Seat Equitation – Walk/Trot

To be shown at a walk and trot.

ACD-9. Western Pleasure (Rider any age)

To be shown a walk, jog and lope.

ACD-10. Western Equitation (Rider any age)

To be shown at a walk, jog and lope.

ACD-11. Western Pleasure – Walk/Trot

To be shown at a walk and jog.

ACD-12. Western Equitation – Walk/Trot

To be shown at a walk and jog.

Open Schooling Division

This division is intended for the novice exhibitor who isn't ready to compete in classes where full show attire is required (i.e. Arabian, Saddlebred, Morgan, etc.). **Riders may show their own horse, a leased horse, or an Academy horse.**

Nominations for this division are by RIDER. **Open to Riders any age.** Riders nominating in this Division may not compete in any other Tri-State breed division except Academy. In order to be eligible to nominate themselves for the Open Schooling Division, riders must not have won a blue ribbon in a class that requires full show attire.

At shows, cross entry is permitted between Open Schooling Division and classes requiring full show attire **with different riders.**

Either show bridles or training equipment (i.e. snaffle bridle, martingale, etc.) is permitted. **Full show attire is not allowed including hunt coats, saddle suits, and/or western show outfits.** Acceptable attire is appropriate to the seat ridden. Saddle Seat: Jodhpurs or dark long pants, dress shirt, tie, boots of jodhpur boot. Hunt Seat: Breeches, ratcatcher shirt, paddock or tall English riding boots. Western: Jeans, appropriate dress shirt and western boots. Vests, sweater vests or sweaters optional. No sport shoes or derbies allowed. Hair to be neat, up and out of the way of the exhibitor's number. **Protective helmets that meet or exceed ASTM standards are encouraged in all seats.**

Neatness of turn out of horse and rider to be considered in all classes. Headers are to be allowed in the ring for the lineup in any Open Schooling Division class at the discretion of the instructor.

Class must be worked both ways of the ring at the required gaits. Horses must stand quietly in the line-up and may be asked to back. Horses should not be asked to perform an extended trot or hand gallop.

Recognized shows offering an Open Schooling Division must clearly state on their prize list and results which classes are Open Schooling Show classes. Classes may be split into appropriate age groups at horse shows.

OSD-1. Hunter Pleasure - (Rider any age)

To be shown at a walk, trot and canter. To be judged on manners, performance, and ability to give a good pleasure ride.

OSD-2. Hunter Pleasure - Walk/Trot

(Rider any age) - To be shown at a walk and trot. To be judged on manners, performance, and ability to give a good pleasure ride.

OSD-3. Hunt Seat Equitation - (Rider any age)

To be judged on rider's skill in achieving class performance, correctness of form for hunt seat. To be shown at a walk, trot and canter and may be asked to perform a simple pattern.

OSD-4. Hunt Seat Equitation - Walk/Trot - (Rider any age)

To be judged on rider's skill in achieving class performance, correctness of form for hunt seat. To be shown at a walk and trot and may be asked to perform a simple pattern.

OSD-5. Western Pleasure - (Rider any age)

To be shown at a walk, jog and lope. To be judged on manners, performance, and ability to give a good pleasure ride.

OSD-6. Western Pleasure - Walk/Trot - (Rider any age)

To be shown at a walk and jog. To be judged on manners, performance, and ability to give a good pleasure ride.

OSD-7. Western Equitation - (Rider any age)

To be judged on rider's skill in achieving class performance, correctness of form for western seat. To be shown at a walk, jog and lope and may be asked to perform a simple pattern.

OSD-8. Western Equitation - Walk/Trot - (Rider any age)

To be judged on rider's skill in achieving class performance, correctness of form for western seat. To be shown at a walk and jog and may be asked to perform a simple pattern.

OSD-9. Showmanship at Halter - (Exhibitor any age)

Exhibitors are being judged on the fitting, grooming, training and showing of their horse. The horse's conformation is not to be considered in the judging of this class. Exhibitors will be asked to walk, trot and pose their horse appropriate to the breed of horse being shown. Whips are optional, **but show attire is not allowed**. Horse Show management may split into age categories. Age appropriate showmanship pattern will be posted before the session begins.

OSD-10. English Pleasure (Rider any age)

To be shown at a walk, trot and canter. To be judged on manners, performance, and ability to give a good pleasure ride.

OSD-11. English Pleasure Walk Trot (Rider any age)

To be shown at a walk and trot. To be judged on manners, performance, and ability to give a good pleasure ride.

OSD-12. Saddle Seat Equitation

To be judged on the rider's skill in achieving class performance and correctness of form for Saddle Seat. To be shown at a walk, trot and canter. May be asked to perform a simple pattern.

OSD-13. Saddle Seat Equitation Walk Trot

To be judged on the rider's skill in achieving class performance and correctness of form for Saddle Seat. To be shown at a walk and trot.

Leadline Division

Leadline - Riders (with their handler) will enter the ring at a walk, reverse and walk the second direction. The judge may call for a trot, jog or pleasure gait at the handler's discretion. To be shown Saddle Seat, Hunt Seat or Western Seat. Attire appropriate to the discipline shown. Side walkers are permitted. Open to riders who have never shown previously in an Academy or Schooling Walk/Trot off lead class. Riders may not cross enter into any other division. Safety helmets are permitted and encouraged.

Leadline Walk and Whoa - Same specifications as Leadline with the addition of the following straight line, four cone pattern. One at a time, at a walk from the lineup, each rider will instruct their mount to Whoa and then Walk on to the next cone. Accompanying handlers will encourage riders to take charge giving the Whoa and Walk command to their horse using voice and leg cues. Lineup per the ringmasters directions. Protective helmets that meet or exceed ASTM standards are required.

Nominated riders will qualify for year-end participation awards upon completing three classes of Leadline, Leadline Walk and Whoa or a combination of the two. Competitors in Leadline and Leadline Walk and Whoa must never have shown in any other Academy or Schooling off lead class.

Dressage Schooling Division

Rules:

1. Annual Tri-State membership dues (\$45) and schooling rider nomination fee (\$20) must be paid prior to points counting.
2. Nominations are made by rider's name, not by horse.
3. Riders not to have ridden over First Level Test 3. This division is for the non-professional.
4. This schooling division consists of two sections.

- A. For riders who are taking lessons and are mounted on horses that are generally owned or leased from a riding school or instructor.
 - B. For riders owning their own horse or leasing a horse from a private party; not a horse from a riding school program.
5. Tack to be determined by Show Management.
 6. All scores must be recorded and submitted to the Tri-State point tally person.
 7. Minimum of three shows with scores from two different judges required to qualify for year end awards.
 8. The median score will be used to determine the end score.
 9. A combination of tests may be used for point tallies within the Walk/Trot Division, Training Level or First Level Divisions.
 10. A Champion and Reserve Champion year end trophy will be awarded in Dressage Walk/Trot, Dressage Walk/Trot Equitation, Training Level and First Level to the rider with the highest score meeting division qualifications.
 11. The Tri-State Dressage Schooling Division is open to riders of all ages and horses of all breeds.

Dressage Walk/Trot

Tests include Intro A, Intro B & Intro C

Equitation riders to show in a class as a group. 1st to 6th place. Not % scores.

DS-1. Dressage Walk/Trot - Rider 10 & Under

DS-2. Dressage Walk/Trot - Rider 11 - 14

DS-3. Dressage Walk/Trot - Rider 15 - 21

DS-4. Dressage Walk/Trot - Adult Rider

Dressage Walk/Trot Equitation

Equitation riders to show in a class as a group. 1st to 6th place. Not % scores.

DS-5. Dressage Walk/Trot Equitation - Rider 10 & Under

DS-6. Dressage Walk/Trot Equitation - Rider 11 - 14

DS-7. Dressage Walk/Trot Equitation - Rider 15 - 21

DS-8. Dressage Walk/Trot Equitation - Adult Rider

Dressage Walk/Trot/Canter Equitation

Equitation riders to show in a class as a group. 1st to 6th place. Not % scores.

DS-9. Dressage Walk/Trot/Canter Equitation - Rider 10 & Under

DS-10. Dressage Walk/Trot/Canter Equitation - Rider 11 - 14

DS-11. Dressage Walk/Trot/Canter Equitation - Rider 15 - 21

DS-12. Dressage Walk/Trot/Canter Equitation - Adult Rider

Training Level

Tests include Test 1, 2, 3

DS-13. Training Level - Rider 10 & Under

DS-14. Training Level - Rider 11 - 14

DS-15. Training Level - Rider 15 - 21

DS-16. Training Level - Adult Rider

First Level

Tests include Test 1, 2, 3

DS-17. First Level - Riders Any Age

Arabian/Half-Arabian Division

Minimum of four (4) classes recommended for division approval. Current USEF toe length and shoe weight will apply for the Arabian/Half-Arabian division. Note: To be eligible for Tri-State awards, exhibitors in Equitation and Showmanship classes must be nominated by name.

ARB-1. Arabian Hunter Pleasure-Open

To be shown at a walk, trot, canter and hand gallop, back readily and stand quietly. To be judged on manners, performance, suitability as a Hunter, quality and conformation. Horse may be braided. Colored brow bands and cavesons, figure eight, drop of flash nose bands prohibited.

ARB-2. Arabian Hunter Pleasure-AOTR/ATR

To be shown and judged the same as Class #ARB-1.

ARB-3. Arabian Hunter Pleasure-JOTR/JTR

To be shown and judged the same as Class #ARB-1.

ARB-4. Arabian/Half/Anglo Arabian Pleasure Driving-Open/AOTD/ATD

To be shown at a walk, normal trot and strong trot. To stand quietly and back readily. To be judged on attitude, manners, performance, quality and conformation.

ARB-5. Arabian Country English Pleasure-Open

To be shown at a walk, normal trot, canter and hand gallop. It is mandatory that horses be asked to halt on the rail, stand, quietly back and walk off on a loose rein at least one direction of the ring. To be judged on attitude, manners, performance, quality and conformation; in that order. It is imperative that the horse give the distinct appearance of being a pleasure to ride. A quiet responsive mouth is paramount. Cross entries are prohibited between the Arabian Country English Pleasure section and the Arabian English Pleasure and Pleasure Driving sections and/or informal Combination classes at the same competition.

ARB-6. Arabian Country English Pleasure-AOTR/ATR & JOTR/JTR

To be shown and judged the same as Class #ARB-5. Exception, no hand gallop.

ARB-7. Arabian Western Pleasure-Open

To be shown on a light rein at a walk, jog-trot and lope and hand gallop. Extreme speed to be penalized. To be judged on manners, performance, suitability of horse to rider, substance and conformation.

ARB-8. Arabian Western Pleasure-AOTR/ATR

To be shown and judged the same as Class #ARB-7.

ARB-9. Arabian Western Pleasure-JOTR/JTR

To be shown and judged the same as Class #ARB-7.

ARB-10. Half-Arabian/Anglo Arabian Country English Pleasure-Open

To be shown and judged the same as Class #ARB-5.

ARB-11. Half-Arabian/Anglo Arabian Country English Pleasure-AOTR/ATR & JOTR/JTR

To be shown and judged the same as Class #ARB-5.

ARB-12. Half-Arabian Hunter Pleasure-Open

To be shown and judged the same as Class #ARB-1.

ARB-13. Half-Arabian/Anglo Arabian Hunter Pleasure-AOTR/ATR

To be shown and judged the same as Class #ARB-1.

ARB-14. Half-Arabian/Anglo Arabian Hunter Pleasure-JOTR/JTR

To be shown and judged the same as Class #ARB-1.

ARB-15. Half-Arabian Western Pleasure-Open

To be shown on a light rein at a walk, jog-trot, lope and hand gallop. To be judged on manners, performance, substance and conformation.

ARB-16. Half-Arabian Western Pleasure-AOTR/ATR & JOTR/JTR

To be shown and judged the same as Class #ARB-15 except they do not hand gallop.

ARB-17. Registered Arabian Halter-Any Age-Open

Entries to be judged individually standing, then at a walk and trot and must be serviceable sound. Emphasis is placed on conformation, type, quality, movement, substance, manners and presence. A suitable headstall with throatlatch is mandatory. A whip or crop is optional.

ARB-18. Registered Half-Arabian Halter-Any Age-Open

Entries to be shown and judged the same as Class #ARB-17.

ARB-19. Arabian or Half-Arabian Mounted Native Costume

To be shown at a walk, trot, canter and hand gallop. Extreme speed to be penalized. Horses to stand quietly and back readily. To be judged 75% on performance and manners; 25% on appointments.

ARB-20. Arabian or Half-Arabian Ladies Side Saddle

To be shown both directions at the walk, trot or jog-trot, canter or lope. Horses should back readily if requested by a judge and stand quietly. To be judged 85% on manners, performance, suitability, quality and conformation; 15% on appropriate side saddle attire. Manners and suitability of purpose shall be emphasized. (Suitability refers to the horse being suitable as a side saddle mount.)

ARB-21. Arabian or Half-Arabian English Show Hack-Open, AOTR, AAOTr, ATR, JOTR, JTR

To be shown at a walk, trot, canter and hand gallop; collected, extended and normal gaits to be called for. To stand quietly and back readily. No more than 12 horses to hand gallop at one time. To be judged on manners, performance, quality and conformation. Refer to USEF Rulebook Chapter VIII.

ARB-22 Arabian or Half Arabian Park Horse

To be shown at a Walk, Trot and Canter. The Walk should be brisk with collection and animation. The Trot should be an animated two-beat gait with good cadence. The Canter should be animated, collected and true on both leads. Loss of form due to excess speed to be penalized. Not required to halt or back.

ARB-23. Arabian/Half-Arabian/Anglo Arabian Dressage-Open, AOTR/JOTR

Intro through Training Level Test 4.

ARB-24. Arabian/Half-Arabian/Anglo Arabian Dressage-Open, AOTR/JOTR

First Level and above.

ARB-25. Arabian/Half-Arabian/Anglo Arabian Showmanship - 7 & Under

Handlers may show English, Hunt or Western attire. If handler shows in Hunt attire, the horse may show with a braded mane and tail. To be judged following USEF rules: Articles 1699D & 1699E.

ARB-26. Arabian/Half-Arabian/Anglo Arabian Saddle Seat Equitation - 17 & Under

Equitation classes must be conducted in accordance with USEF Rules, Articles 2203 & 2204. The arena gate must remain closed during the rail work and the pattern.

ARB-27. Arabian/Half-Arabian/Anglo Arabian Hunt Seat Equitation - 17 & Under

To show and be judged the same as Class #ARB-25.

ARB-28. Arabian/Half-Arabian/Anglo Arabian Western Horsemanship - 17 & Under

To show and be judged the same as Class #ARB-25.

ARB-29. Arabian/Half-Arabian/Anglo Arabian-Walk-Trot/Walk-Jog Pleasure

Open to riders 10 years and old and under. A rider must never have been judged in a class at an affiliated show that required a canter or lope. Open to Saddle Seat, Hunt Seat or Western Seat. Entries to enter the ring at a WALK. To be shown both directions of the ring at the walk and trot or jog only. Entries will line up on command. Judge may request riders individually back their horses in the line-up. The horse must give the appearance of being a safe and suitable mount for the class. The safety of all exhibitors must be of primary consideration when judging these classes. Stallions prohibited.

ARB-30 Arabian/Half-Arabian/Anglo Arabian-Walk-Trot/Walk-Jog Equitation

Open to riders 10 years old and under. Class specification the same as Class #ARB-28. Riders will not be asked to perform any tests except for backing in the line-up.

Registered Morgan Division

Minimum of eight (8) classes recommended for division approval. In Pleasure, Natural Park and Stock classes, shoe and pad (inclusive) not to exceed 18 oz.; toe, including shoe and pad, not to exceed 4-3/4"; other performance classes no weight limit but length of toe, including shoe and pad, not to exceed 5-3/4". In Classic Pleasure classes, shoes must not exceed 16 oz.; no pads, and length of toe must not exceed 4-1/2" No bars, turn-buckles or bands. Stallions prohibited in Junior Exhibitor classes.

MOR-1. Park Saddle Horse - Open

To be shown at a park walk, park trot and canter and to be judged on quality, presence, performance with proper cadence and balance, and manners 60%; type and conformation 40%. Championships judged 50%/50%.

MOR-2. Classic Pleasure Saddle Horse- Amateur/Ladies

To be shown at a walk, pleasure trot, road trot and canter. To be judged on manners, performance with proper cadence and balance, and gait 60; type and conformation 40. It is imperative that the horse give the distinct appearance of being a pleasure to ride with emphasis on the walk and smooth transitions. Horses must stand quietly and back readily. To be shown by an amateur in saddle seat attire only. Attendants must be amateurs or individuals eligible for amateur status.

MOR-3. Classic Pleasure Saddle Horse - Junior Exhibitor

Same specs as class #69 except rider must be 17 & under. Stallions prohibited.

MOR-4. Classic Pleasure Driving

To be shown to an appropriate vehicle at a walk, pleasure trot and road trot. It is imperative that the horse give the distinct appearance of being a pleasure to drive, with emphasis on the walk and smooth transitions. Horses must stand quietly and back readily. To be shown by an amateur in appropriate attire. Headers must be amateurs or individuals eligible for amateur status. To be judged on manners, performance with proper cadence and balance, & gait 60%; type and conformation 40%.

MOR-5. English Pleasure Horse - Open/Ladies

To be shown at a walk, pleasure trot, road trot and canter, with light rein, but still maintaining contact with horse's mouth. To be judged on manners, performance with proper cadence, quality, presence and apparent ability to give a good pleasure ride 60%; type and conformation 40%. Championships judged 50%/50%.

MOR-6. English Pleasure Horse - Junior Horse - (4 years old and under)

Same specifications as Class #MOR-5, except age of horse. May also earn points in Junior/Novice classes.

MOR-7. English Pleasure Horse - Amateur/Ladies

Amateurs must be in receipt of current amateur certification. Other specifications same as Class #MOR-5.

MOR-8. English Pleasure Horse - Junior Exhibitor

Same specs as class #MOR-5 except rider must be 17 & under. This class also judged on suitability. Stallions prohibited.

MOR-9. Western Pleasure Horse - Open/Ladies

To be shown at a walk, jog trot and lope, with light rein, but still maintaining contact with horse's mouth. Judge may ask for extension of any gait. To be judged on manners, performance with proper cadence and balance, quality, presence and apparent ability to give a good pleasure ride, with emphasis on manners and gait 60%; type and conformation 40%. Championship judged 50%/50%.

MOR-10. Western Pleasure - Junior Horse (4 years old and under)

Same specifications as Class #MOR-9, except age of horse. May also earn points in Junior/Novice classes.

MOR-11. Western Pleasure Horse - Amateur/Ladies

Amateurs must be in receipt of current amateur certification. Other specifications same as Class #MOR-9.

MOR-12. Western Pleasure Horse - Junior Exhibitor

Same specs as class #MOR-9 except rider must be 17 yrs. & under. Also judged on suitability. Stallions prohibited.

MOR-13. Western Seat Equitation - Rider 17 & Under

Open to Amateur or Junior riders who have not reached their 18th birthday. To be judged on hands, seat and general horsemanship ability. Horses to be shown at a walk, jog and lope and at such maneuvers as the judge may request. USEF rules prevail. Tests 1-5. Stallions prohibited.

MOR-14. Pleasure Driving - Open

To be shown at a walk, pleasure trot and road trot. To be judged on manners, performance with proper cadence and balance,

quality, presence and apparent ability to give a good pleasure drive 60%; type and conformation 40%. Championships judged 50%/50%.

MOR-15. Hunter Pleasure - Open/Ladies

To be shown at walk, trot, extended trot, canter and extended canter, with light rein but still maintaining contact with horse's mouth. Horse may be braided. To be judged on performance with proper cadence and balance, manners, and soundness 60%; type and conformation 40%. Championships judged 50%/50%.

MOR-16. Hunter Pleasure - Junior Horse (4 years old and under)

Same specifications as Class #MOR-15, except age of horse. May also earn points in Junior/Novice classes.

MOR-17. Hunter Pleasure - Amateur/Ladies

Amateurs must be in receipt of current amateur certification. Other specifications same as Class #MOR-15.

MOR-18. Hunter Pleasure - Junior Exhibitor

Same specs as class #MOR-15 except rider must be 17 & under. This class also judged on suitability. Stallions prohibited.

MOR-19. Hunt Seat Equitation - Rider 17 & Under

Open to Amateur or Junior riders who have not reached their 18th birthday. To be judged on hands, seat and general horse-horsemanship ability. Horses to be shown at a walk, trot and canter and at such maneuvers as the judge may request USEF rules prevail. Tests 1-19. Stallions prohibited.

MOR-20. Saddle Seat Equitation - Rider 13 & Under

Open to Junior riders who have not reached their 14th birthday. To be judged on hands, seat and general horsemanship ability. Horses to be shown at a walk, trot and canter and at such maneuvers as the judge may request. USEF rules prevail. Tests 1-12. Stallions prohibited.

MOR-21. Saddle Seat Equitation - Rider 14-17

Open to Amateur Junior riders who have reached their 14th but not their 18th birthday. To be judged on hands, seat and general horsemanship ability. Horses to be shown at a walk, trot and canter and at such maneuvers as the judge may request. USEF rules prevail. Tests 1-16. Stallions prohibited.

MOR-22. Equitation Walk/Trot - Rider 11 & Under Combined Award

Open to riders 11 years old and under. Rider must not have ever been judged in a class at a recognized or non-recognized show that required a canter or lope. Points will be earned in Walk/Trot Saddle Seat, Hunt Seat or Western Seat classes - but will count toward a single year-end Championship trophy. Points will count in whichever style Walk/Trot Equitation class is offered at each show. Riders are eligible to earn points in all three riding style classes.

MOR-23. Pleasure Walk/Trot - Rider 11 & Under Combined Award

Open to riders show age 11 & under. Rider must not have ever been judged in a class at a recognized or non-recognized show that required a canter or lope. To be judged on suitability, manners, performance with proper cadence, quality, presence and apparent ability to give a good pleasure ride 60% ; type and conformation 40%. Horses will earn points in English, Hunt or Western Pleasure Walk/Trot classes and points will count

towards a single year end award. Horses may earn points in whichever of the three Walk/Trot Pleasure classes offered at each show and horses may earn points in all three riding styles.

MOR-23. Registered Morgan In-Hand – Any age – Open

Entries to be judged individually standing, then at a walk and trot and must be serviceably sound. Emphasis is placed on type and conformation with consideration given to horse's ability to move correctly on the lead. Only two handlers allowed per horse.

Registered Hackney Pony Division

1. All ponies must be registered with American Hackney Horse Society and/or Canadian Hackney Society. Must be entered in their full registered names, with registration numbers, and under the names of the owners of record with the AHHS or the CHHS.

2. Stallions are prohibited in Jr. Exhibitor classes.

3. A pony may be shown in only one of the four sections Hackney (short or cob-tail), Hackney Harness (long-tail), Hackney Roadster, or Hackney/Harness Pleasure Driving Pony) at the same competition. **One change of section per year per owner of record with the AHHS is permitted.** If a particular horse show does not offer a Hackney/Harness Pleasure Driving Pony section, pleasure ponies may enter the Hackney, Harness or Roadster Pony section without jeopardizing their eligibility in the Hackney/Harness Pleasure Driving Pony section at subsequent competitions.

4. Ponies that lose their Maiden, Novice, Limit or other classification in the Harness Pony section shall not regain their classification when shown in the Hackney Pony section.

5. Protective headgear is mandatory in all Roadster Pony to Bike, Roadster Pony Under Saddle and Pleasure Pony Under Saddles classes.

Height:

- ♦ For competition purposes, the maximum height of Hackney ponies is 14.2 hands, the maximum height of Harness ponies is 12.2 hands and the maximum height of Roadster Ponies is 13 hands.

- ♦ Ponies may not be shown in a performance class unless the owner possesses a current measurement card or valid measurement form issued by USA Equestrian. The measurement of Hackney Ponies over 12.2 hands will not be necessary unless the classes are divided according to height rather than sex.

Roadster Ponies: If entries warrant, two sections can be offered:

- a) Roadster Ponies 48-50" & Under
- b) Roadster Ponies Over 50-52".

HP-1. Single Roadster Pony - 52" & Under - Open, Limit or Junior

To be shown to a bike at a jog-trot, road gait and then at speed. Judged on performance, speed, quality and manners.

HP-2. Single Roadster Pony - 52" & Under - Amateur

To be shown to a bike at a jog-trot, road gait and then at speed. Judged on suitability, manners, performance, speed and quality.

HP-3. Single Roadster Pony - 52" & Under - Junior Exhibitor

To be shown to a bike at a jog-trot, road gait and then at speed.

HP-4. Junior Exhibitor Roadster Pony Under Saddle - 52" & Under

To be shown by a junior exhibitor only, under English saddle, martingale, open bridle with snaffle bit, single or double rein and protective boots. Rider to wear stable colors, jacket and protective headgear to match. To be shown first at a jog-trot and road gait, then reversed and shown at a jog-trot, road gait and then at speed. To be judged on manners, performance, speed and quality. Saddle classes do not qualify a pony for harness championships.

HP-5. Single Harness Pony - Amateur or Ladies

To be shown to a viceroy or other suitable vehicle. To show all-around action at a park trot and not faster. To be driven in the half cheek with side checks, appear to have perfect mouths, must stand quietly and back easily. Ponies must be checked, but the checks may be adjusted during the line up. During a workout, those remaining in the center of the ring may be unchecked. Not an Appointments Class. To be judged on manners, quality and performance.

HP-6. Single Harness Pony - Open, Limit or Junior

To be shown at a park trot and "show your pony." To be judged on performance, quality and manners.

HP-7. Single Hackney Pony (short or cob-tail) - Amateur or Ladies

To be shown to a viceroy or other suitable vehicle. To show all-around action at a park trot and not faster. To be driven in the half cheek with side checks, appear to have perfect mouths, must stand quietly and must back easily. Ponies must be checked, but the checks may be adjusted during the line up. During a workout those remaining in the center of the ring may be unchecked. Not an Appointments Class. To be judged on manners, quality and performance.

HP-8. Single Hackney Pony (short or cob-tail) - Open, Limit or Junior

To be shown at a park trot and "show your pony." To be judged on performance, quality and manners.

HP-9. Single Hackney (or) Harness Pony Pleasure Driving - Amateur or Jr. Exhibitor

Open to registered Hackney Ponies 14.2 hands and under. Jr. Exhibitors and Amateurs only. Open to Mares and Geldings only. Longtails and Cobtails shown together, unless management deems they have enough entries to offer two divisions; switches or artificial tails may be added. One attendant without whip is permitted to head each pony only during the line up. The header may stand the entry on its feet and then must stand three paces back from the pony and is not allowed to touch the pony except for safety purposes. It is imperative that ponies stand quietly, back readily and return to the lineup.

Appointments include: appropriate harness (black or russet) with low crupper, sidecheck or overcheck, square or round blinkers, snaffle. Martingale optional, checkbit mandatory, no braids. Must be shown to an appropriate vehicle either a two-wheeled basket type jog-cart or road bike with basket. Ponies shall remain checked in the line up and may not be adjusted, unless an additional workout is called, at which time, ponies remaining in the line up may be unchecked. To be shown at a flat walk, pleasure trot and road trot (showing a distinct difference in gait). Excessive speed and laboring motion to be penalized. Judge's emphasis should be on ability to give a pleasurable drive while retaining a show attitude. To be judged on performance and conformation. Ponies must stand quietly and are required to back.

Ponies cannot cross enter between Hackney, Harness or Roadster Pony classes at the same competition. The use of artificial appliances or devices such as chains, shackles and rubber bands are prohibited on the grounds before or during the competition.

HP-10. Hackney Pleasure Pony Under Saddle – Youth Exhibitor

To be shown under English saddle, open bridle with snaffle bit single or double reins, (martingale optional), full bridle (curb bit and snaffle) or Pelham (without martingale) acceptable. Braids or artificial devices are not allowed. Rider attire to be dark jodhpurs, shirt, tie, vests (optional), riding boots, gloves and hair neatly held back so the number is easily read. Riding suits, fitted vests and hats (other than protective headgear) are prohibited. To be shown at a flat walk, pleasure trot, and a road trot. To be judged on suitability, manners, performance and quality. Saddle classes do not qualify a pony for harness championships.

Roadster Horse to Bike

RTB-1 Open/Amateur/Youth/Ladies

To be shown first at a jog trot and road gait. Then reversed and shown at a jog trot, road gait and then at speed. To be judged on performance, speed, quality and manners. Ladies class suitable for and driven by a lady. Classes containing more than 10 entries will be split.

Registered American Saddlebred Division

Minimum of twelve (12) classes (Show Horse, Pleasure Horse or Saddle Seat Equitation sections) recommended for division approval.

*Owners and trainers at USEF recognized competitions rated "A" in all Saddlebred sections must be current members in good standing with the American Saddlebred Horse Assoc., Inc. (USEF rule 2004)

ASB PERFORMANCE HORSE SECTION

HORSES ENTERED IN THIS SECTION MAY NOT SHOW IN THE SADDLEBRED "PLEASURE HORSE SECTION" AT THE SAME SHOW.

ASB THREE-GAITED

To be shown with roached mane at an animated walk, park trot, and canter.

ASB-1. ASB Three-Gaited - Open

To be judged on performance, presence, quality, manners and conformation.

ASB-2. ASB Three-Gaited - Junior Exhibitor - Rider 17 and under

To be judged on manners, performance, presence, quality and conformation. Stallions prohibited.

ASB-3. ASB Three-Gaited - Ladies - Rider 18 and Over

Shown by a lady. To be judged on manners, quality, presence, performance and conformation. Stallions prohibited.

ASB-4. ASB Three-Gaited - Amateur

To be judged on manners, performance, presence, quality and conformation.

ASB-5. ASB Three-Gaited - Junior (4 years old & under)

To be judged on performance, presence, quality, manners and conformation.

ASB FIVE-GAITED

To be shown with a full mane and tail at a walk, trot, slow-gait, rack and canter.

ASB-6. ASB Five-Gaited - Open

To be judged on performance, presence, quality, manners and conformation.

ASB-7. ASB Five-Gaited - Junior (4 years old & under)

To be judged on performance, presence, quality, manners and conformation.

ASB-8. ASB Five-Gaited - Junior Exhibitor - Riders 17 and under

To be judged on manners, performance, presence, quality, and conformation. Stallions prohibited.

ASB-9. ASB Five-Gaited - Amateur

To be judged on manners, performance, presence, quality and conformation.

ASB-10. ASB Five-Gaited - Ladies - Rider 18 and Over

Shown by a Lady. To be judged on manners, quality, presence, performance and conformation. Stallions prohibited.

ASB FINE HARNESS

ASB-11. ASB Fine Harness - Open

To be shown with full mane and tail to an appropriate light four-wheeled vehicle, light harness; snaffle bit and over-check required. Shown at an animated walk, park trot, "Show Your Horse", extreme speed to be penalized, to stand quietly. To be judged on performance, presence, quality, manners and total conformation.

ASB-12. ASB Fine Harness - Amateur

Other specs same as Class #ASB-11.

ASB-13. ASB Fine Harness (4 yrs old & under)

Same specifications as Class #ASB-11 except age of horse.

ASB THREE-GAITED PARK HORSE

Horses should be stylish with finish and quality and well-mannered. The performance should be animated and graceful in all gaits. Tail may be natural or set. Horses entered in this class are INELIGIBLE TO ENTER CLASSES IN ASB PERFORMANCE OR ASB PLEASURE DIVISIONS AT THE SAME SHOW. May show in Model and In-Hand classes or in any other division for which they are qualified.

ASB-14. ASB Three-Gaited Park - (Full Mane & Tail) - Open

To be shown at animated walk or flat walk, trot, and canter. To be judged on performance, manners, presence, quality and conformation. Horses to stand quietly.

ASB-15. ASB Three-Gaited Park - (Full Mane & Tail) - Amateur

Same specs as Class #ASB-14 except ridden by an Amateur.

ASB-16. ASB Three-Gaited Park - (Full Mane & Tail) -

In-State Horsemen's Association

Junior Horse

Same specs as Class #ASB-14 except age of horse.

ASB PLEASURE HORSE SECTION

Horses entered in these classes may not enter Saddlebred Performance Horse classes at the same show. Cross entry between Show Pleasure and Country Pleasure or between Three-Gaited and Five-Gaited classes at the same show is prohibited, however, horses shown in any Saddlebred Pleasure class may show in Saddlebred Pleasure Equitation or in any other division for which they are qualified. STALLIONS PROHIBITED.

To be shown by a Junior or an Amateur. **HORSES MAY NOT BE SHOWN BY A PROFESSIONAL IN ANY OPEN PERFORMANCE PLEASURE CLASS AT THE SAME SHOW.**

Entries must be shown with a full mane and tail. The fact that a horse's tail has once been set does not exclude participation. The use of artificial appliances or devices such as chains, shackles, rubber bands, blinkers (except when driving) or blindfolds are prohibited on the grounds before or during a competition. Any animal with prohibited equipment must be disqualified from further competition.

To be judged at a flat walk, trot and canter (plus slow-gait and rack in 5-Gaited classes.) Manners and suitability as a pleasure mount are paramount. Transitions from one gait to another should be smooth and effortless. Horses must be obedient with prompt transitions. Special emphasis is placed on a true, flat walk. Light contact with the horse's mouth must be maintained. Must stand quietly and back readily in the line-up. To be penalized: pulling, head tossing, laboring action, going sideways and tail-switching.

ASB SHOW PLEASURE

Horses may wear tailsets or bustles, but may not show with the tail gingered, tied or braced & unset tails will not be penalized. Braids & inconspicuously applied hair in mane and tail permitted. Shoe bands and pads permitted. Quarter boots permitted only in the Five-Gaited classes. Judged 75% on manners, performance, presence and quality; 25% on total conformation. (May not enter Country Pleasure Classes at same show)

ASB-17. ASB Three-Gaited English Show Pleasure - Rider 13 & Under

ASB-18. ASB Three-Gaited English Show Pleasure - Rider 14-17 Years

ASB-19. ASB Three-Gaited English Show Pleasure - Rider 18-38

ASB-20. ASB Three-Gaited English Show Pleasure - Rider 39 & Over

ASB-21. ASB Three-Gaited English Show Pleasure - Junior Horse (4 years old & under)

ASB-22. ASB Show Pleasure Driving - Horse Any Age

To be shown to a suitable two-wheeled jog cart with driver only; light harness with snaffle bit and separate overcheck required; quarter boots prohibited; at flat walk, trot and extended trot, speed to be penalized.

ASB-23. ASB Show Pleasure Driving - Junior Horse - (4 years old and under)

Same specs as Class #ASB-22 except age of horse.

ASB-24. ASB Five-Gaited Show Pleasure

Shown at a flat walk, trot, slow gait, rack at MODERATE speed and canter.

ASB COUNTRY PLEASURE

Horses to be plain shod (no bands, pads or device between hoof and shoe). No braids or added hair permitted. (See ASB Pleasure Section heading for more information.) Judged 75% on manners, performance, presence and quality; 25% on total conformation. Entries must be asked both ways of the ring to halt and stand quietly on the rail. (May not enter Show Pleasure classes at same show).

ASB-25. ASB Three-Gaited English Country Pleasure - Rider 13 & Under

To be shown at a flat walk, trot, extended trot and canter. Horses required to halt and stand quietly on the rail both ways of ring; light contact with mouth; to stand quietly and back readily in line up. To be judged 75% on manners, performance, presence and quality; 25% on conformation and neatness of attire.

ASB-26. ASB Three-Gaited English Country Pleasure - Rider 14-17

ASB-27. ASB Three-Gaited English Country Pleasure - Rider 18-38

ASB-28. ASB Three-Gaited English Country Pleasure - Rider 39 & Over

ASB-29. ASB 5-Gaited Country Pleasure

To be shown at a flat walk, trot, extended trot, slow gait, rack at moderate speed and canter. Judged 75% on manners, performance, presence and quality; 25% on total conformation.

ASB-30. ASB Hunter Country Pleasure - Amateur

To be shown at a walk, trot, extended trot, canter and hand gallop both ways of the ring. For safety reasons, the judge may limit the number of horses to hand gallop at one time. Horses are required to stop and back on the rail. To be judged on manners, performance, suitability as a hunter, quality and conformation. In the line, horses must stand quietly with all four legs perpendicular to the ground. Horse shall be required to back readily in the line.

ASB-31. ASB Three-Gaited Western Country Pleasure

To be shown at a flat walk, jog-trot, and lope on a reasonably loose rein without undue restraint (ridden with one hand on reins).

ASB-32. ASB Country Pleasure Driving

To be shown at a flat walk, trot & extended trot. Speed to be penalized. Entries must be shown both ways of the ring and asked to halt and stand quietly on the rail.

ASB PARK PLEASURE

The ASB Park Pleasure Horse should be stylish with finish and quality and well mannered. The performance should be animated and graceful at all gaits. Horses shown in this division are ineligible to show in ASB Performance or ASB Pleasure Division at the same show, but may show in Model or In-Hand classes or in any other division for which they qualify. May wear tailsets or bustles, but may not show with tail gingered, tied or braced and unset tails will not be penalized. Use of artificial appliances or devices such

as chains, shackles, rubber bands, blinkers or blindfolds are prohibited on the grounds before or during the show. Must be shown with full mane and tail. STALLIONS PROHIBITED.

ASB-33. ASB Park Pleasure – Open

Shown at a flat walk, trot and canter. Horses must stand quietly and back readily in the line-up. Judged 75% on manners, performance, presence and quality; 25% on total conformation.

ASB-34. ASB Park Pleasure – Amateur

Same specs as Class #ASB-33 except ridden by an amateur.

ASB-35. ASB Park Pleasure - Junior Horse (4 yrs & Under)

Same specs as #ASB-33 except age of horse.

ASB PLEASURE EQUITATION

ASB-36. ASB Pleasure Equitation - Rider 13 & Under

Juniors who have not reached their 14th birthday. To be shown with full mane and tail which must not be gingered or put in an artificial device which alters the natural tail carriage in preparation for the show. USEF Tests 1-10. Riders competing in this class may not enter any other Saddle Seat Equitation class at the same show except UPHA Challenge Cup, USEF Medal and NHS Good Hands Classes, but may compete in open Saddle Seat Equitation Championship IF NO Pleasure Equitation Championship is offered.

ASB-37. ASB Pleasure Equitation - Rider 14-17

Same specifications as Class #ASB-36, except rider age. USEF Tests 1-16.

MODEL AMERICAN SADDLEBRED

ASB-38. Model American Saddlebred - Open

Horses to be judged according to the standards for the ideal American Saddlebred type and conformation. Horses are to enter the ring at a walk and immediately line-up per Ringmaster's direction. Entries are to be judged on conformation and finish only and are not to be moved on the line; way of going is not to be considered.

ASB SINGLE BIT

ASB-39 Single Bit Walk/Trot

Classes are open to Amateur and Juvenile riders in a snaffle bit only (no curb bit or curb chains allowed) with a running martingale, German martingale or draw rein. All tack should be of show ring quality. Riders are to wear appropriate show ring attire. Horse/rider combinations may not cross enter into another division, with the exception of Model or Showmanship. Shown at a flat walk and trot both ways of the ring. Entries must stand quietly in the line-up. Not to back.

ASB-40 Single Bit Walk/Trot/Canter

Same specifications as ASB-39. Shown at a flat walk, trot and canter both ways of the ring.

ASB CLASSIC PLEASURE HORSE

ASB-41 Three-Gaited Classic Pleasure – Saddle Seat Equipment

Full mane and tail. Open to Amateur and Junior Exhibitors. Horse must exhibit a natural, relaxed manner. Its headset should com-

Open Performance Division

plement its natural conformation. Horse must be plain shod, rim pads or a single pad (no wedge pads or bands). The walk should be flat-footed and ground covering with light to medium contact. The Trot should be four-cornered and fluid, not labored, executed at medium speed. The Classic Pleasure horse should trot on the rail, canter with light to medium rein contact and be straight, correct and organized on both leads. It should give the appearance of smooth, quiet, collected and comfortable. Aggressive speed or choppiness to be penalized. At all gaits the Classic Horse should appear to be suitable for an entry-level rider, regardless of the experience of the current rider. To be judged 80% on manners and way of going and 20% on conformation.

Saddle Seat Equitation Division

Minimum of three classes recommended for division approval, however, these classes may not be offered in conflict with a how having Saddle Horse Division approval. (NOTE: USEF Medal Class and UPHA Challenge Cup Class will not count towards Tri-State points.) To be judged on hands, seat and general horsemanship ability. Horses must show at a walk, trot and canter and at such maneuvers as the judge may request. USEF rules prevail. Stallions prohibited. **Open to riders on any breed of horse.**

SSE-1. Saddle Seat Equitation - Rider 10 & Under

Juniors who have not reached their 11th birthday. USEF tests 1-7.

SSE-2. Saddle Seat Equitation - Rider 11-13

Juniors who have reached their 11th birthday, but not their 14th birthday. USEF tests 1-12.

SSE-3. Saddle Seat Equitation - Rider 14-17

Juniors who have reached their 14th birthday, but not their 18th birthday. USEF tests 1-16.

SSE-4. Saddle Seat Equitation - Rider 18-38

Amateur Riders who have reached their 18th birthday, but not their 39th birthday. Points will NOT be counted from classes limited to Saddlebred Pleasure Horses.

SSE-5. Saddle Seat Equitation - Rider 39 & Over - Amateur

Same specifications as Class #SSE-4, except rider age.

SSE-6. Saddle Seat Equitation - Rider 10 & Under - Walk/Trot Class

Open to riders 10 years and under. To be judged on the rail at a walk and trot only. Rider must not have ever been judged in a class at a recognized or non-recognized show that required a canter. It is recommended that a class having 12 or more entries be divided. If a division is necessary, the recommended split is to divide the entries into a class for riders 8 years old and under and one for riders 9 and 10 years old. No tests shall be called.

Riders showing in Walk/Trot/Canter classes, in any discipline, on any breed horse are not eligible to return to Walk/Trot classes.

OP-1. Open English Pleasure - Any Breed or Type - Rider 10 & Under

Mane and tail may be trimmed, set or natural. To be shown at a walk, trot or pleasure gait, and canter on a reasonably loose rein. Judged on manners, performance and suitability to pleasure riding. May show in any other division for which they are qualified.

OP-2. Open English Pleasure - Any Breed or Type - Rider 11-17

Same specs as Class #OP-1, except rider age.

OP-3. Open English Pleasure - Any Breed or Type - Rider 18-38

Same specs as Class #OP-1, except rider age.

OP-4. Open English Pleasure - Any Breed or Type - Rider 39 & Over

Same specifications as Class #OP-1, except rider age.

OP-5. Open English Pleasure - Any Breed or Type - Adult Rider - Walk/Trot

Same as Class OP-1 except to be shown at a walk & trot only. Rider must never have shown in a walk/trot/canter class.

OP-6. Open English Pleasure - Any Breed or Type - Rider 10 & Under - Walk/Trot

Same as Class #OP-1 except to be shown at a walk & trot only.

OP-7. Open Pleasure Driving - Any Breed or Type

To be shown to a suitable two-wheeled pleasure cart at a walk, trot or pleasure gait and extended gait. Judged on manners, performance and suitability to pleasure driving. Entries should stand quietly and back readily in the line-up. May show in any other division for which they are qualified.

OP-8. Open Western Bridle Path - Any Breed or Type - Rider any Age

To be shown with full mane and tail at a walk, ANIMATED trot or pleasure gait and canter. To be judged on performance, manners, and substance. Curb chains permissible if at least 1/2" wide and lying flat against the horse's jaw.

OP-9. Open Hunter Pleasure

Open to any breed of horse. Rider any age. To be shown in appropriate hunter attire. Horses may be braided. Regulation snaffles, pelhams and full bridles, all with cavesson nose bands are recommended. Martingales of any type are prohibited. To be shown at a walk, trot or pleasure gait and canter both ways of the ring. Light contact with the horse's mouth is required. Horses should be obedient, alert, responsive and move freely. Judges may ask horses to hand gallop collectively, one way of the ring. No more than eight will be asked to hand gallop at one time.

OP-10. Open Hunt Seat Equitation - Rider Any Age

Open to riders on any breed of horse. To be shown in appropriate hunter attire at a walk, trot or pleasure gait and canter both ways of the ring. Judge may ask for hand gallop one way of the ring. Judged on hands, seat and general horsemanship ability. Workouts at judge's discretion.

OP-11. Open Western Pleasure - Any Breed or Type - Rider Any Age

To be shown at a flat-foot walk, jog trot or pleasure gait and lope both ways of the ring on a reasonably loose rein without undue restraint. Horses should stand quietly and back readily. To be judged on performance and obvious ability to give a good pleasure ride with a calm, relaxed way of going, with emphasis on manners.

OP-12. Open Western Seat Equitation - Rider Any Age

Open to riders on any breed of horse. To be shown in appropriate western attire at a flat-foot walk, jog trot or pleasure gait and lope both ways of the ring. Judged on hands, seat and general horsemanship ability. Workouts at judge's discretion.

OP-13. Open English Pleasure – Amateur Rider – Any Breed or Age

Same specs as Class OP-1. Amateur riders only.

OP-14. Open Hunter Pleasure - Any Breed or Type – Rider 12 and Under Walk/Trot

Same specs as class #OP-9 except to be shown at a walk and trot only.

OP-15. Open Western Pleasure – Any Breed of Type – Rider 12 and Under Walk/Jog

Same specs as class #OP-11 except to be shown at a walk & jog only.

OP-16. Open Showmanship at Halter – Any Breed or Type – Any Age Handler

Exhibitors are judged by how they present the horse while performing a specific pattern. Horse should be mannerly and well groomed; handler poised, confident and neatly attired.

Registered Tennessee Walking Horse Division

MODEL/HALTER CLASS

TWH-1. Plantation, Lite Shod, Trail Pleasure, All Day Pleasure and Country Pleasure - Open

PLANTATION PLEASURE CLASSES

The Plantation Pleasure Horse should perform the true walking gaits and in the same manner as the Lite Shod Pleasure Horse. The major difference between a Plantation Pleasure Horse and a Lite Shod Pleasure Horse is the larger shoe allowed in the Plantation Pleasure Division which may produce a more animated and powerful appearing front end. The Plantation Pleasure Horse should still perform its gaits effortlessly without the appearance of laboring. Plantation Pleasure Horses are not allowed to cross-enter into Lite Shod Pleasure, Trail Pleasure, Country Pleasure or All Day Pleasure classes, but may show in other open classes for which they qualify.

TWH-2. Plantation Pleasure English - Open - 2 Gait

TWH-3. Plantation Pleasure English - Open - 3 Gait

TWH-4. Plantation Pleasure English - Amateur - 2 Gait

TWH-5. Plantation Pleasure English - Amateur - 3 Gait

TWH-6. Plantation Pleasure Western - Open - 2 Gait

TWH-7. Plantation Pleasure Western - Open - 3 Gait

TWH-8. Plantation Pleasure Amateur/Owned/Trained - 2 Gait - Optional Tack

TWH-9. Plantation Pleasure Amateur/Owned/Trained - 3 Gait - Optional Tack

TWH-10. Plantation Pleasure Juvenile Rider - 2 Gait - Optional Tack

TWH-11. Plantation Pleasure Junior Horse - 2 Gait - Optional Tack

LITE SHOD PLEASURE CLASSES

The Lite Shod Pleasure Horse should display brilliance and show presence while performing true walking gaits. The horse should be collected and well balanced, in that not one element of the horse should stand out from all other qualities when considering gait, form, rhythm or conformation. Compared to the Trail Pleasure horse, the ideal Lite Shod Pleasure horse should have a higher head carriage and exert more energy through collection while maintaining its walking ability and overall presence. The Lite Shod Pleasure Horse should break higher with its front legs than a Trail Pleasure Horse in all gaits and should not be penalized for this unless it appears unnatural to the horse or out of balance with all other elements of the horse. Form is not to be sacrificed for speed. Manners are paramount for a pleasure horse and should be given serious consideration in judging. The horse should have an alert and willing attitude, be manageable with light to medium rein contact, and must back readily. Any evidence of being behind the bit should be penalized. Lite Shod Pleasure horses cannot cross-enter into Plantation, Trail Pleasure, Country Pleasure or All Day Pleasure classes at the same show.

TWH-11. Lite Shod Open English - 2 Gait

TWH-12. Lite Shod Open English - 3 Gait

TWH-13. Lite Shod Amateur English - 2 Gait

TWH-14. Lite Shod Amateur English - 3 Gait

TWH-15. Lite Shod Open Western - 2 Gait

TWH-16. Lite Shod Open Western - 3 Gait

TWH-17. Lite Shod Amateur/Owned/Trained - 2 Gait - Optional Tack

TWH-18. Lite Shod Amateur/Owned/Trained - 3 Gait - Optional Tack

TWH-19. Lite Shod Juvenile Rider - 2 Gait - Optional Tack

TWH-20. Lite Shod Junior Horse - 2 Gait - Optional Tack

TRAIL PLEASURE CLASSES

The Trail Pleasure Horse must perform the true walking gaits efficiently and with effortlessness geared toward encouraging stamina and longevity as a pleasant, working saddle horse. The horse should exhibit a true, four beat walking gait with pronounced and cadenced head nod. The horse should be well balanced, in that not one element of the horse should stand out from all other qualities when considering gait, form, rhythm or conformation. A horse exhibiting a crampy or gimmicky way of going must be excused. Animation and action are not desired in a Trail Pleasure Horse; front legs should not break higher than 45 degrees from the vertical. The ideal Trail Pleasure Horse will reach out in front and pull with its shoulders. The front legs can move close to the ground as long as the power is coming from a loose shoulder and the horse has head shake and is square and on four corners. The Trail Pleasure Horse should be on the bit and not strung out in frame. It should carry its head in a natural and relaxed position. The horse must be extremely well mannered, responsive and quiet. The horse must be manageable on a light rein at all gaits. The horse must stand quietly and back readily on command. Trail Pleasure horses may be asked to stop on the rail at any time during the class to demonstrate manners and a willing attitude. The Trail Pleasure Horse's canter should be relaxed and consistent with no sign of effort from the rider. Additionally, if specified on the class list, Trail Pleasure horses will be asked to do a Trail Walk as the last gait called for both ways of the ring. The Trail Walk is a true walk with a loose rein and no appearance of strain on the part of the horse or rider. The appearance should be that of a pleasure riding horse that is relaxed, content and manageable. Trail Pleasure horses are not allowed to show in Lite Shod Pleasure, Plantation Pleasure, Country Pleasure or All Day Pleasure classes at the same show, but they are eligible to show in halter and versatility classes at the same show.

- TWH-21. Trail Pleasure Open English - 2 Gait**
- TWH-22. Trail Pleasure Open English - 3 Gait**
- TWH-23. Trail Pleasure Amateur English - 2 Gait**
- TWH-24. Trail Pleasure Amateur English - 3 Gait**
- TWH-25. Trail Pleasure Open Western - 2 Gait**
- TWH-26. Trail Pleasure Open Western - 3 Gait**
- TWH-27. Trail Pleasure Amateur/Owned/Trained - 2 Gait - Optional Tack**
- TWH-28. Trail Pleasure Amateur/Owned/Trained - 3 Gait - Optional Tack**
- TWH-29. Trail Pleasure Juvenile Rider - 2 Gait - Optional Tack**
- TWH-30. Trail Pleasure Junior Horse - 2 Gait - Optional Tack**

COUNTRY PLEASURE CLASSES

The Country Pleasure horse should display true pleasure qualities, along with the natural gaits of the Tennessee Walking Horse; a Country Pleasure horse should never have a tendency to rack, pace or trot. Front leg animation (lift) is not desirable and head-shake is not required to be as deep as that of the other Walking horse divisions. The Country Pleasure horse should exhibit a balanced, smooth, four-cornered, gliding flat walk and the running walk. The canter should be relaxed and consistent with no sign of effort from the exhibitor. Manners are paramount in this division. The Country Pleasure horse must be ridden with a light or relaxed rein contact. The Country Pleasure horse should stand quietly in the lineup. The Country Pleasure horse may be ridden English or Western (as determined by the class description), but not a combination of both. Riders may use two hands with English or Western, but must then maintain two-hand rein hold throughout duration of class. Cavessons are allowed in English classes only.

The Country Pleasure horse may cross-enter into All Day Pleasure classes, but not cross-enter into Trail Pleasure, Lite Shod, Plantation Pleasure classes at the same show. (Exception: Spotted Saddle horse classes and all Versatility, Model, Showmanship and Equitation).

- TWH-31. Country Pleasure English - 2 Gait**
- TWH-32. Country Pleasure English - 3 Gait**
- TWH-33. Country Pleasure Western - 2 Gait**
- TWH-34. Country Pleasure Western - 3 Gait**
- TWH-35. Country Pleasure Juvenile Rider - 2 Gait - Optional Tack**
- TWH-36. Country Pleasure Junior Horse - 2 Gait - Optional Tack**
- TWH-37. Country Pleasure Amateur English - 2 Gait**
- TWH-38. Country Pleasure Amateur English - 3 Gait**
- TWH-39. Country Pleasure AOT - 2 Gait**
- TWH-40. Country Pleasure AOT - 3 Gait**
- TWH-41. Country Pleasure Amateur Western - 2 Gait**
- TWH-42. Country Pleasure Amateur Western - 3 Gait**

ALL DAY PLEASURE CLASSES

The All Day Pleasure division is open to all gaited breeds and may be ridden English or Western (as determined by the class description), but not a combination of both. Neat attire is required and should include a collared shirt, long pants, and heeled boots. Exhibitors wearing show attire shall not be favored by the judge. If an ADP horse is exhibited in Western tack, the rider may use two hands on the reins, but both hands shall remain on the reins the duration of the class. Braided manes or forelocks are not required. These classes will allow up to a 3/4" wide by 3/8" thick shoe and will be judged as Pleasure classes. Classes are judged on the horse/rider team that exhibits a true, natural, smooth ride that one would want to ride "all day." Manners, calmness, obedience, and a smooth, consistent gait are paramount in the All Day Pleasure classes. The All Day Pleasure horse must be ridden with a light or relaxed rein contact. The All Day Pleasure class may be a two or three gaited class. As long as shoeing requirements are met, All Day Pleasure horses are allowed to cross-enter into Country Pleasure, however may not cross-enter into Trail Pleasure, Lite Shod, Plantation Pleasure classes at the same show. (Exception: Spotted Saddle horse classes, Racking horse classes and all Versatility, Model, Showmanship and Equitation).

Required Gaits of All Day Pleasure Classes:

Trail Walk is a true walk with a loose rein and no appearance of strain on the part of the horse or rider. The appearance should be that of a pleasure riding horse that is relaxed, content, and manageable.

Pleasure Gait is to be performed at moderate speed and can be a variation of any saddle horse gait with no preference given to any particular gait over another. The gait should be consistent and balanced and should appear easy and comfortable to ride. Excessive speed is not a desired trait. Manners are paramount in this division. Horses should stand quietly and back readily. Positive credit will be given to horses that display such qualities as responsiveness, steadiness, manners, and traveling on a loose rein.

Canter is on a light rein and of medium to slow speed. Pumping of the reins or anything appearing rushed or out of control shall be severely penalized.

TWH-43. All Day Pleasure English - 2 Gait

TWH-44. All Day Pleasure English - 3 Gait

TWH-45. All Day Pleasure Western - 2 Gait

TWH-46. All Day Pleasure Western - 3 Gait

**TWH-47. All Day Pleasure Juvenile Rider - 2 Gait -
Optional Tack**

**TWH-48. All Day Pleasure Junior Horse - 2 Gait -
Optional Tack**

TWH-49. All Day Pleasure Amateur English - 2 Gait

TWH-50. All Day Pleasure Amateur English - 3 Gait

TWH-51. All Day Pleasure AOT - 2 Gait

TWH-52. All Day Pleasure AOT - 3 Gait

TWH-53. All Day Pleasure Amateur Western - 2 Gait

TWH-54. All Day Pleasure Amateur Western - 3 Gait

Ranch Horse Division

Minimum of (3) classes recommended for Division Approval. Note to all members: Same general rules apply to this Division as all others regarding dues, nomination fees and Point System. Please see Page 1 for full details.

The Tri-State Association approved Ranch Horse Division is dedicated to promoting the all around working horse, regardless of breed. Approved shows consist of seven classes designed to simulate the type of work typical of what a ranch horse might perform. All classes are open to all breeds, all aged horses and all ages of riders.

MANDATORY RULES FOR RANCH HORSE CLASSES

Working tack shall be used. An excessive show of silver on saddles or bridles is not allowed. All competitors shall wear western clothing. This will include a long sleeved shirt with a collar, western boots with a heel, and a western hat. Management may determine and announce whether long-sleeved shirts or short sleeved shirts are more appropriate for the existing weather.

Severe bits will not be allowed in any class. Prohibited equipment includes wire chin straps, jerk lines, tack collars, and tie downs with metal in contact with the horse's head. Tie downs will only be allowed in the timed event class.

A horse may be shown in a hackamore (bosal) at any age, but only while they are five years old and younger may two hands be used on the reins. Protective boots will be allowed in all performance classes. Split reins are allowed in all classes. Roping reins are allowed in barrel racing and roping classes. A roma rein may be used in any class.

R-1. Ranch Horse Conformation - Mares - Exhibitor 18 & Over

Designed to showcase the conformation necessary for a ranch horse to do the job under saddle. Horses are ridden into the ring for judging, one at a time, lined up, ground tied and stripped. After inspection horses are re-saddled and may be led or ridden out of the ring.

R-2. Ranch Horse Conformation - Mares - Youth Exhibitor 17 & Under

All other specs same as Class #R-1.

R-3. Ranch Horse Conformation - Stallions & Geldings - Exhibitor 18 & Over

Other specs same as Class #R-1.

R-4. Ranch Horse Conformation - Stallions & Geldings - Youth Exhibitor 17 & Under

Other specs same as class #R-1.

R-5. Ranch Horse Pleasure - Rider 18 & Over

Designed to show a ranch horse that is a pleasure to ride. Horses are required to work both ways in the arena at a walk, jog or pleasure gait and lope. The walk is intended to cover ground. The jog or pleasure gait should be faster than the walk. The extended jog or pleasure gait is truly extended, with longer more ground covering strides. The lope is a true 3 beat gait that is to be extended into a hand gallop, showing ground covering extension without excessive speed. Horses to reverse at the trot or pleasure gait in one direction and reverse at a lope the other direction. Simple or flying lead changed allowed.

R-6. Ranch Horse Pleasure - Youth Rider 17 & Under

Other specs same as Class #R-5.

R-7. Ranch Horse Versatility - Rider 18 & Over

This class features obstacles a ranch horse may encounter in daily work. Pattern and obstacles will be posted prior to class. May include, but not limited to gate work, trailer loading, simple pattern or maneuvers to show handiness, dragging obstacles, use of a rope, checking feet, ground tying, trot-overs (or pleasure gait), jump not to be over 12 inches at its highest point and to be walked or trotted over, moving objects from one area to another, etc. Judge's discretion at number of refusals for an obstacle.

R-8. Ranch Horse Versatility - Youth Rider 17 & Under

Other specs same as Class #R-7

R-9. Working Cow Horse - Rider 18 & Over

This class consists of only cow work. Scoring emphasis shall be based on the horse maintaining control of the cow at all times, exhibiting superior cow sense and natural cow working ability without excessive reining and spurring. Cow work must be completed within two minutes. This class demonstrates a horse's ability to work a single cow and is divided into three parts.

- ♦ Holding or boxing a cow at the end of the arena long enough to show control.
- ♦ Taking the cow down the fence and turning it at least once in each direction.
- ♦ Circling the cow in the middle of the arena once in each direction.

The judge takes into consideration the size of the arena, condition of ground and the disposition and degree of difficulty exhibited by the cattle worked.

- ♦ The contestants shall be penalized for general bad manners such as:
 - Biting, running over cow, hanging up on the fence, failure to hold the cow at the end of the arena, exhausting cow before circling, are all three point (3) deductions.
 - Failure to show sufficient control of cow when circling is two points (2).
 - Running past cow is one point (1) for every cow length.
 - Deliberate spurring or use of romal forward of cinch results in a five point (5) deduction.
- ♦ The following are causes for a zero (0) score:
 - Horse that turns it's tail to the cow.
 - Use of two hands on reins except with junior horses ridden in bosal or snaffle bit.
 - Horse that runs over a cow causing fall of horse and rider.

The following characteristics of the horse are considered faults and will be penalized at discretion of the judge:

- ♦ Exaggerated opening of mouth
- ♦ Nervous throwing of head
- ♦ Lugging on bridle
- ♦ Losing a cow
- ♦ Being unable to finish a pattern because of a bad cow

R-10. Working Cow Horse - Youth Rider 17 & Under

Other specs same as Class #R-9.

R-11. Ranch Cutting - Rider 18 & Over

This class is designed to show a horse's ability to separate a cow from the herd, hold that cow away from the herd and then drive the cow away from the herd and pen it. The three (3) minute time will begin when a rider crosses a time line just prior to entering

the herd. The rider will then separate one cow from the herd and work it for approximately 30 seconds before driving it to the opposite end of the arena and penning it.

The whistle will be blown at the one minute point in the run to let the contestant know to then pen the cow. A rider will be disqualified if he fails to pen the cow at the end of three minutes, or if the cow returns to the herd after it has been clearly separated from the herd. The contestant will have two turn back riders and two herd holders. When the one minute whistle is blown, these helpers will immediately move out of position to the sides of the arena and allow the contestant to drive the cow past them and into the pen. A horse is judged on its ability to handle the cow. Reining of the horse is allowed during this class.

R-12. Ranch Cutting - Youth Rider 17 & Under

Other specs same as Class #R-11.

R-13. Barrel Racing - Rider 18 & Over

This is a timed event. The standard cloverleaf pattern is to be used with the contestant having the option of running to either the left or right barrel first. Two stop watches and a flag man will be used if an electronic eye is unavailable. A five-second penalty will be assessed for each barrel down at the end of the run. Either or both hands may be used on the reins. A contestant is disqualified if the pattern is broken.

R-14. Barrel Racing - Youth Rider 17 & Under

Other specs same as Class #R-13.

R-15. Ranch Reining - Rider 18 & Over

Pattern will be posted in the show office one hour before start of class. Horses are to be judged on their ability to perform five basic sets of maneuvers- rollbacks, circles and lead changes, stopping, backing, and spins. Each of these five parts will receive equal credit of fifteen points.

Rollbacks (15 points): At the end of the stop, the rollback should be a 180-degree turn, where the horse turns and leaves in one motion. Short, choppy rundowns will be penalized, as will bouncy, forced stops and rollbacks that come out at less than 180 degrees.

Circles and lead changes (15 points): To be judged on the horse's ability to be willingly guided without pulling to the inside or to the outside of the circle, and on his ability to demonstrate his willingness to increase or decrease speed, and on his ability to change leads, front and back, smoothly with a minimum of cueing from the rider. In the circle segment, the rider can increase his score by making his circles come together at the "same midpoint of the arena," making large circles the same size on each side, small circles the same size on each side and lead changes at the center of the arena. This will demonstrate control to the judges.

Stopping and backing (15 points): To receive maximum credit, a horse should approach the stop loping or galloping freely, willingly moving forward in a straight line, and gradually increasing his speed. The stop should be straight and square, and give the appearance of stopping because he is trained to stop, not because he is forced to stop. As in the rollback maneuver, maximum credit will be given to the horse that approaches the stop running straight, gradually increasing speed, stops straight and square, hesitates momentarily. Short, choppy, checky-looking rundowns, bouncy stops, head throwing, excessive open mouth and resistance on the part of the horse will be penalized.

Maximum credit will be given to the horse that backs straight and then backs willingly in a straight line for at least fifteen feet. If the horse backs crooked, throws head, opens mouth excessively and shows resistance, the horse will be penalized.

Spins (15 points): In order to receive maximum credit, a horse should do at least two spins in each direction. Credit will be given to the horse that spins flat and smooth, showing no indication of being forced, and demonstrates a willing attitude. Forced speed

should not score higher than moderate willing speed. Horses will be penalized for elevated hoppy, forced, or extremely slow spins. The horse that spins smoothly, with moderate speed, keeping his hind quarters in the same general area, and demonstrating good footwork in front should receive the greatest amount of credit.

R-16. Ranch Reining - Youth Rider 17 & Under
Other specs same as Class #R-15.

WORKING RANCH HORSE PATTERNS

PATTERN 1

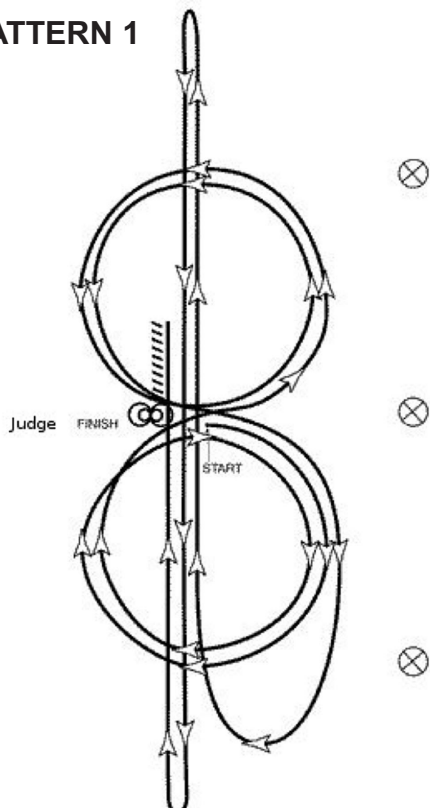

Reining Pattern #1

1. Beginning at the center, take a right lead and do two circles to the right at moderate size and speed.
2. At the center of the arena, change leads and do two circles to the left at moderate size and speed.
3. At the center of the arena, change leads.
4. Do a half circle to the end of the arena and begin run down near the approximate center of the arena, run the length of the arena past the end marker.
5. Stop and rollback to the left. Continue to other end of arena past the end marker.
6. Stop and rollback to the right. Continue to center of arena past the center marker.
7. Stop, and back to the center of the arena or at least 10 feet (3 meters.) Let horse settle in approximate area of stop.
8. Do two spins to the left.
9. Do two spins to the right.
10. Hesitate to show completion of pattern.

PATTERN 2

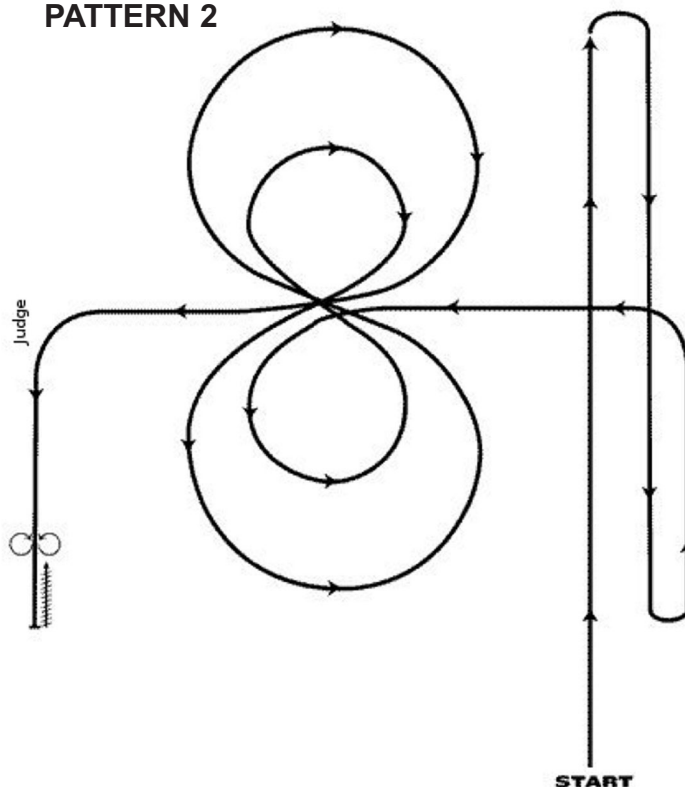

Reining Pattern #2

1. Start on right end of arena and lope to far end of arena.
2. Stop and rollback to the right. Continue to other end of arena.
3. Stop and rollback to the left. Continue to center of arena.
4. Lope a small, slow circle to left. Change leads.
5. Lope a small, slow circle to right. Change leads.
6. Lope large fast circle to left. Change leads.
7. Lope large fast circle to right. Change leads.
8. Continue to the end of the arena.
9. Stop and back 10 to 15 feet.
10. Do two spins to the left.
11. Do two spins to the right.
12. Hesitate to show completion of pattern.